

Seattle's Purpose Built - Pump-Shed

- NEW PRODUCT

Designed & constructed to stand the test of time.

Seattle was looking for a shed that could handle the requirements of irrigation, but we couldn't find one that fitted the bill. So we designed our own.

Small garden sheds are not up to the challenge, not enough height, too flimsy and not enough options for the professional irrigator. Electricians quite often have to build a separate stand to hang the cabinets on.

Seattle's Pump-Shed frame is constructed from galvanised RHS and covered in custom orb. The Pump-Shed comes in panels that easily screw together to form a rigid and strong structure.

There are 2 main options / styles both 2.7m wide x 2.4m deep

- Bus-stop style
- Enclosed and lockable

So if you need a shed for you pump, please consider Seattle's Pump-Shed

- Purpose designed & built
- Simple erection
- Robust Heavy Duty Construction
- Suitable for Direct Mounting of antenna masts
- Integral Mounting structure for Aurora meter box & motor control units
- Available Do It Yourself or fully installed
- Lockable Enclosed option with built in heat dissipation
- Value for money against the garden shed option



Easily Mount Starters / VSD's

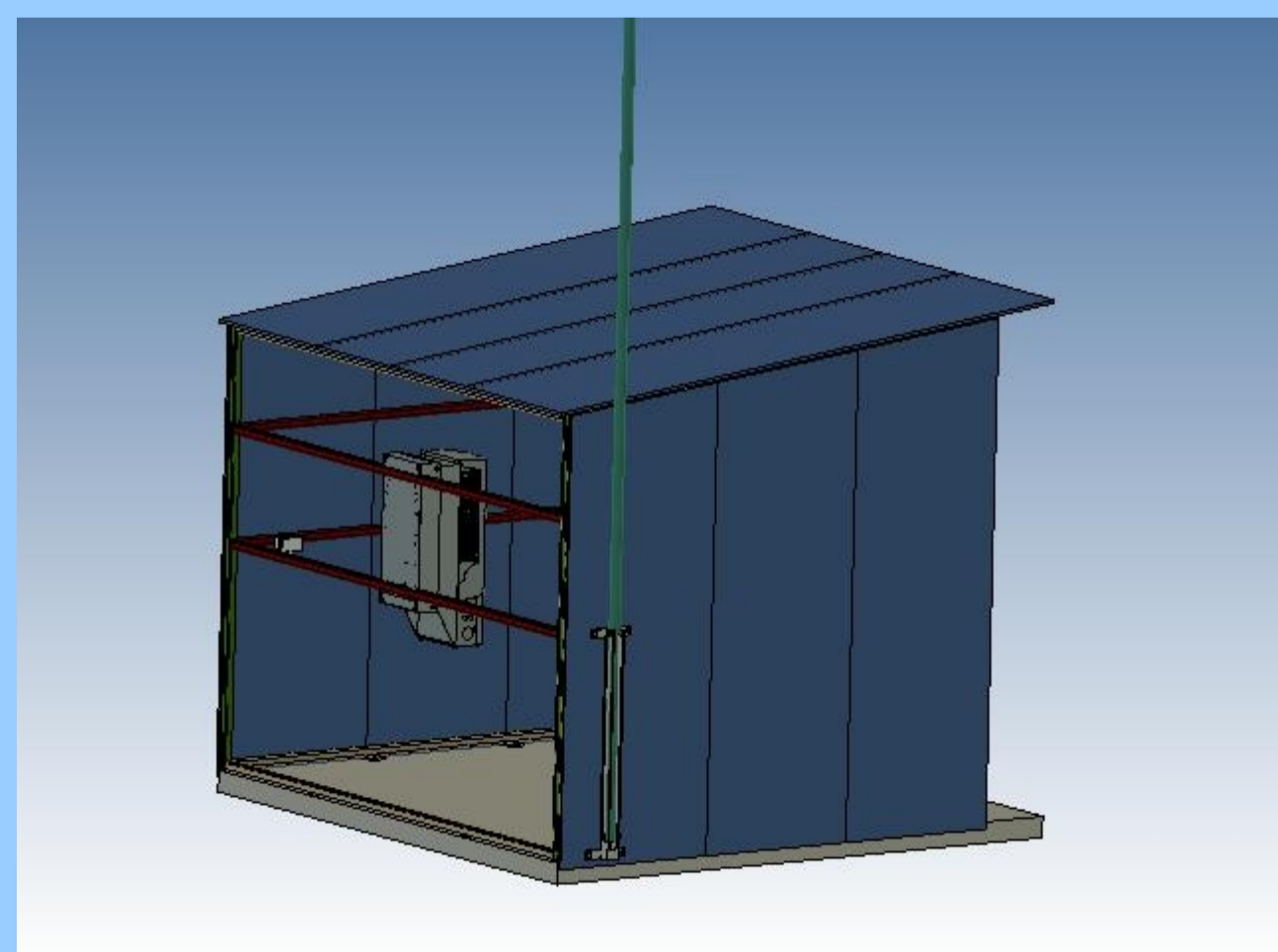

4 Basic Panels

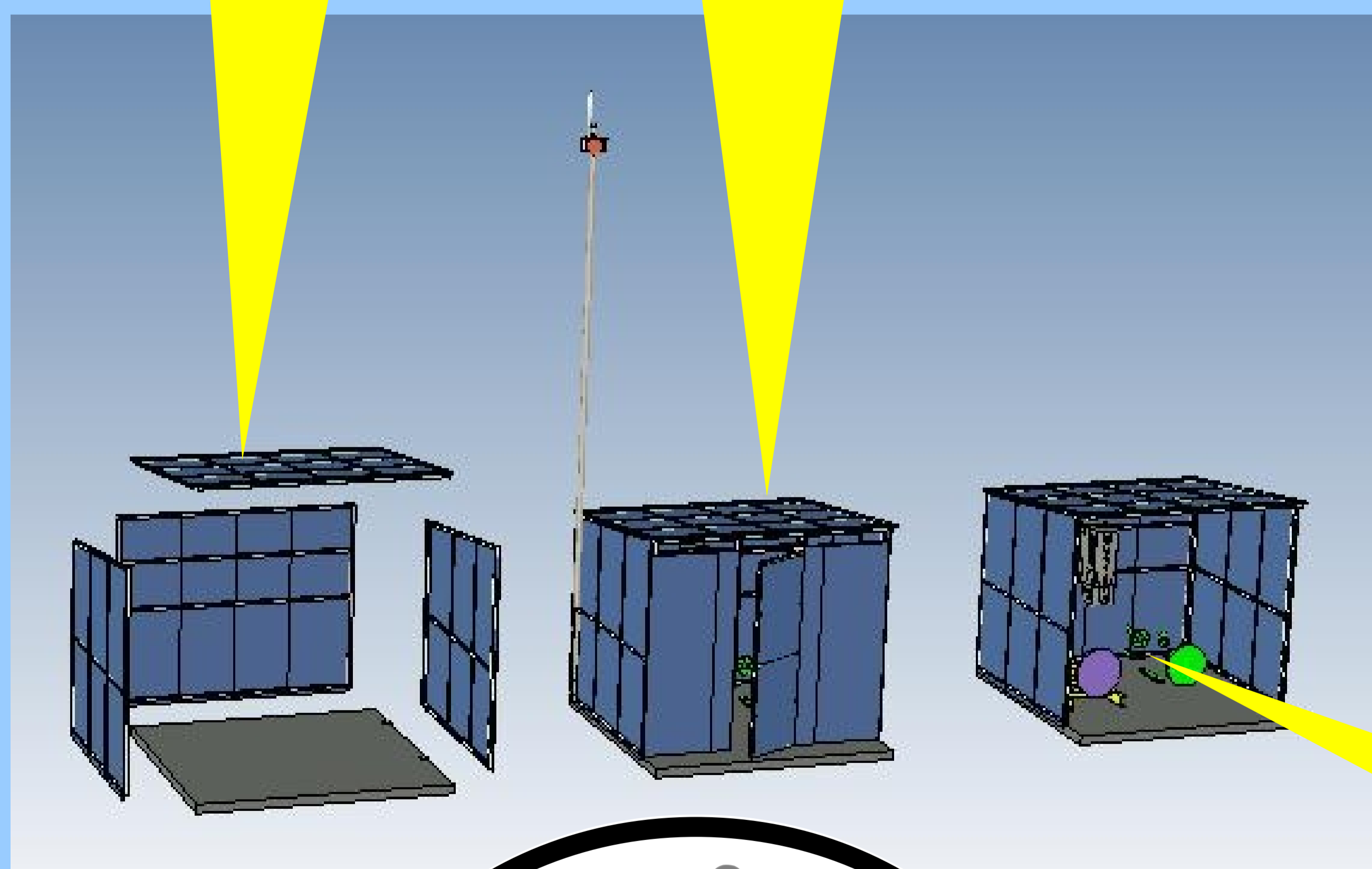

Enclosed & lockable Pump-Shed

Aurora Meter box



Open Bus-stop style Pump-Shed

For more information about **Pump-Shed**
Contact

SEATTLE

on (03) 6496 1263



SEATTLE Irrigation
SERVICES PTY LTD Excellence
Since 1978
Tasmanian Owned