

Dairy Wash Down Monitor

HIGH PERFORMANCE

Value

Safe

Easy

Tough

Green

What makes this monitor so good?

- Smart Design
- minimum rotating elements
- no precision bearings
- tough easy to change seals
- interchangeable nozzles
- proven range tube

This monitor (or cannon as it is sometimes known) **dramatically out-performs** both -

- **lower cost hose units** on the market, and with no hose to worry about, it is also safer.
- **higher cost stainless steel units** on the market and is far more economical to maintain.

How? - **Longer Effective Range**

'Use less and do a better job'

- less water
- fewer monitors required

Flow Rates – 6 to 30 l/s

Pressure – typically 400 to 500 kpa

Max. Recommended Pressure 600 kpa

Max Pressure Rating 1,200 kpa

Order Code – **DWDM#050150 (c/w nozzle)**

specify nozzle Eg 0.9

- Range of nozzles available 17.8mm to 33mm
Imperial Sizes 0.7, 0.8, 0.9, 1.0, 1.1, 1.2, 1.3
- Other models under development.

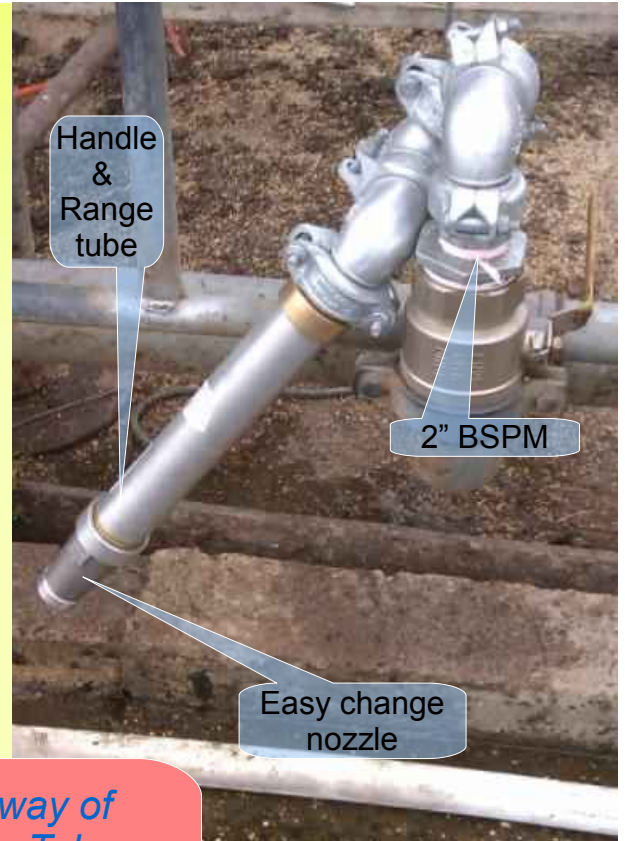

Cutaway of Range Tube showing internal fins

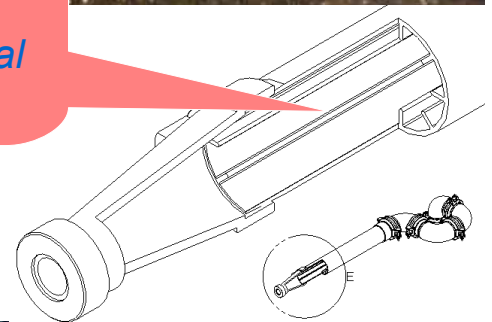

© Designed & manufactured in Tasmania by -
Seattle Services Pty Ltd sales@seattleservices.com.au
 1442 Kimberley Rd Tel (03) 6496 1263
 Merseylea TAS 7305 Fax (03) 6496 1628
 AUSTRALIA www.seattleservices.com.au

Available from -